



WD-153 OPTIFLOW

RACK CONVEYOR DISHWASHER



FEATURES

- User-friendly – Ergonomically designed to provide a good working environment
- The WD-Touch display guides you through the washing process with an intuitive touch screen. Easy navigation with built-in user manuals.
- Low operating costs and a reduced environmental impact
- OPTIFLOW-functions:
 - Provides superior control of the dish process
 - Washes and rinses no empty spaces
 - Optimised rinsing water consumption from 0.9 litre of rinsing water per basket regardless of capacity
 - Optimum use of rinsing water with unique double feed
- Triple rinse for reduced final rinse water consumption
- Excellent wash results – Long washing zones with powerful pumps
- Long service life and easy servicing – Made entirely of stainless steel
- Improved hygiene with vertical self emptying wash- and rinse pumps
- Choice of 6 different contact times
- Electrical connection of PRE-RINSE by the dishwasher
- PRE-RINSE using excess water from the dishwasher
- Electricity and water connections from top
- Drain integrated in the machine for easy cleaning and draining
- ECO-FLOW – condensing unit with heat recovery by the exhausted steam
- Wash arms in stainless steel, with quick fit/removal function. Easily cleaned and without endcovers
- Removable doors for the periodical cleaning
- Timer start, machine ready for wash
- Easy servicing - the machine is serviced from the front
- Singel lever for emptying the tanks, automatic closing of tanks when refilling is starting
- Monitoring system of the machine's various functions
 - Panel which displays the information
- Web Tool with HACCP documentation
- Contactor* for entry and exit conveyor

*Note! It's always necessary to specify the motor power of the conveyor. If not specified, protective motor switch of 0,63-1A will be delivered.

OPTIONS

- Pre-rinse zone L=400 mm
- Drying zone WD-T60 L=600 mm, insulated. Power 3,3 kW.
 - Stand with grid shelf
 - Stand with plane shelf
- Drying zone WD-T80, to turn track L=820 mm, insulated, for connection to the machine together with 90°/180° bar-fedded or machine driven WD turn track. Power 3,3 kW.
- Double drying zone WD-T90 L=900 mm, insulated. With stand. Power 6,6 kW.
 - Grid shelf
 - Plane shelf
- Divided between machine and drying zone
- 230V/3/50Hz
- Marine version and other voltage selection on request
- Steam heated design, steam pressure 50-149 kPa
- Steam heated design, steam pressure 150 - 250 kPa
- Break tank included with booster pump
- Booster heater 12 kW for re-circulating final rinse
- RO-water connection
- Stainless pipes and couplings in final rinse
- Cold water connection
- Water connection from floor
- Timer for pre-rinse
- Timer for through-rinse
- Timer for chain-rinse
- Contactor for control of pre-rinse without timer
- Contactor for pre-rinse with booster pump
- Connection power restriction for example Sicotronic
- External power indication
- Auto self cleaning of wash zone
- Auto self cleaning of condens batteri
- Auto self cleaning of wash zone + condens batteri
- Web Tool with HACCP documentation for cost- and consumption report
- Possibility to interlock the booster heater

EXTRA EQUIPMENT

- Conduit for connection cable, L=1200 mm

WASHING ZONES

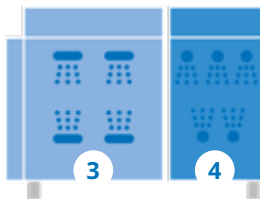

Zone	Zone length in mm
WD-153	
Loading hood	170
3 Chemical wash	900
4 Triple final rinse	585
Length	1655*

* Installation dimensions at bench height.

TECHNICAL DATA	WD-153
Pump, pre-wash (kW)	-
Pump, chemical wash 1 (kW)	1.5
Pump, chemical wash 2 (kW)	-
Pump, chemical wash 3 (kW)	-
Pump, recirculating final rinse (kW)	0.11
Fan, heat recovery (kW)	0.12
Motor, feeder (kW)	0.12
Booster heater 1 (kW)	9*
Booster heater 2 (kW)	9
Heater, chemical wash 1 (kW)	12
Heater, chemical wash 2 (kW)	-
Heater, chemical wash 3 (kW)	-
Heat recovery unit, cooling area (m ²)	25
Fan heat recovery, capacity (m ³ /h)	100
Tank volume, pre-wash tank (litres)	-
Tank volume, wash tank 1 (litres)	100
Tank volume, wash tank 2 (litres)	-
Tank volume, wash tank 3 (litres)	-
Tank volume, final rinse tank (litres)	6
Weight, dishwasher in operation (kg)	490
Degree of protection (IP)	55

* Interlocked if needed, see capacity

CAPACITY AND OPERATING DATA	WD-153
Capacity normal wash (baskets/h)	70-150*
Capacity according to DIN 10510 (baskets/h)	80
Max capacity interlocked booster heater (baskets/h)	150
Cold water consumption, final rinse normal (litres/basket)**	1.3
Energy consumption (% of connected power)	70-90%
Steam consumption*** (kg/h)	50
Environmental temperature at 20°C room temperature (°C)	35
Sound level**** (dB(A))	68

* Maximum capacity 260 baskets/h.

** In combination with the PRM the water consumption is further lowered with 0.1 litre

*** For steam-heated dishwasher

**** Measured 1 metre from the side of the machine

CONNECTION, ELECTRICALLY HEATED DISHWASHER	WD-153
Total connected power (kW) interlocked booster heater (kW)*	23.6
Total connected power (kW)	32.6
Main fuse 400V 3N~(A)**	50
Max. connection area 400V 3N~(L1-L3, N, PE) Cu (mm ²)	35

* See capacity

** Other voltages on request

CONNECTION, STEAM-HEATED DISHWASHER 150-250 KPA*	WD-153
Total connected power (kW)	1.8
Main fuse 400V 3N~(A)	16
Max. connection area 400V 3N~(L1-L3, N, PE) Cu (mm ²)	25
Steam connection (internal thread)	R ¾"
Condensation connection (internal thread)	R ½"

* Other pressures on request.

CONNECTION, WATER, DRAIN AND VENTILATION	WD-153
Water quality, hardness (°dH)	2-7
Hot water connection 50-65°C (internal thread)	R ½"
Cold water connection 5-12°C (internal thread)	R ½"
Drain connection, PP pipe (ø mm)	50
Water capacity, pressure (kPa)	250-600
Water capacity, flow (litres/min)	11
Floor drain, capacity (litres/sec)	3
Heat load to the room (total, sensible, latent) (kW)	7.5 / 4.5 / 3.0

SIZE AND WEIGHT FOR TRANSPORT, STANDARD DISHWASHER*	WD-153
Size** (LxWxH (m))	2.1x0.8x2.0
Weight** (kg)	400

* Normal delivery in 1 piece, If necessary the machine can be further dismantled

** Packaging included

CONNECTION, ADDITION OF DRYING ZONE	Power (KW)	Main fuse 400V 3N~(A)	Installed length (mm)
Drying zone WD-T60 + WD-153	35.9	63	600 + 1655
Drying zone WD-T90 + WD-153	39.2	63	900 + 1655
Drying zone hood WD-T80 for turn track + WD-153	35.9	63	820 + 1655
Drying zone hood WD-T60F free-standing + WD-153	35.9	63	600

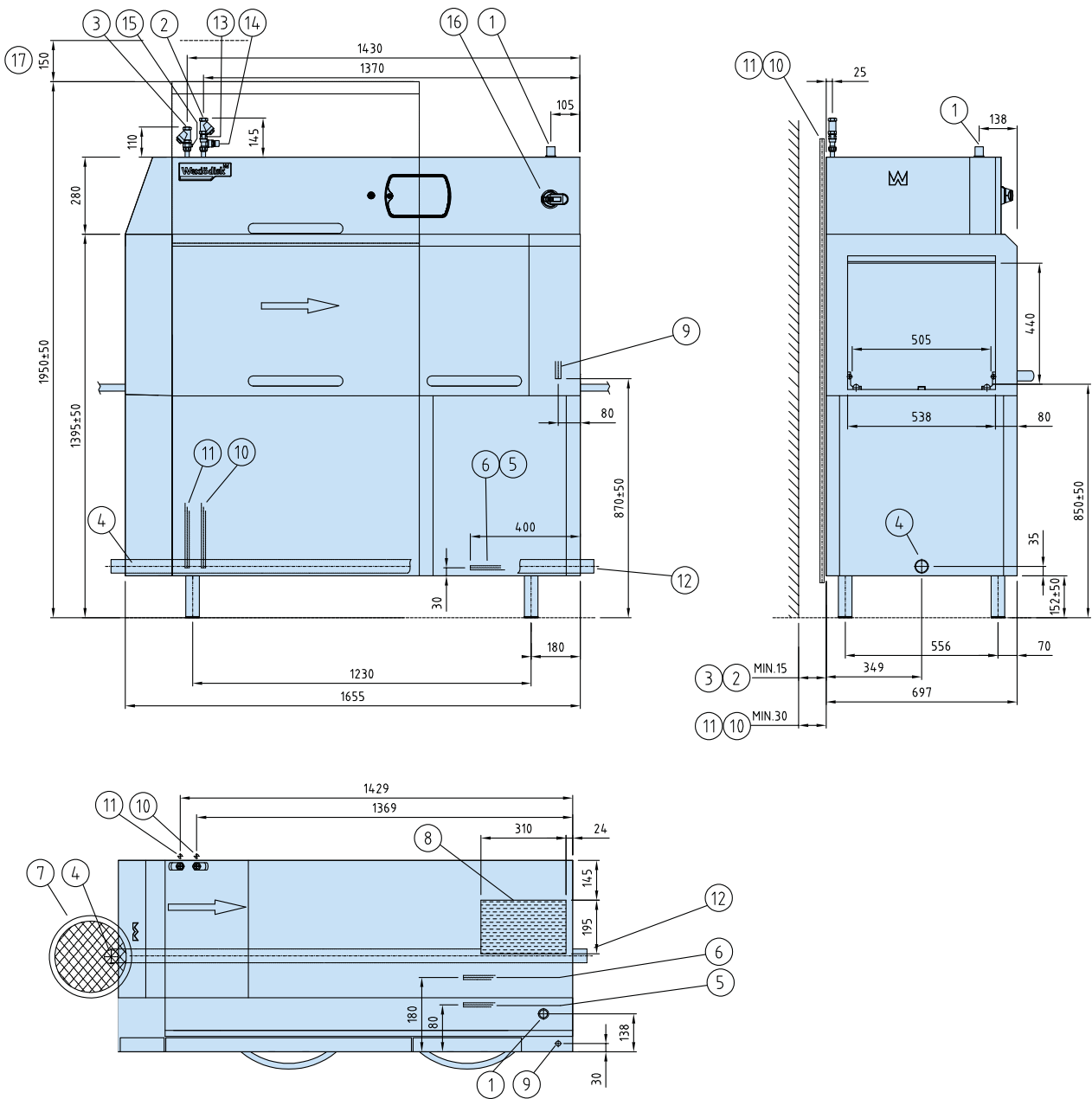

1. Electrical connection
2. Cold water connection/filter R $\frac{1}{2}$ " 250-600 kPa 11 l/min
3. Hot water connection/filter R $\frac{1}{2}$ " 100-600 kPa
4. Drain connection \varnothing 50
5. Steam connection R $\frac{3}{4}$ " (331-421 R") 150-250 kPa
6. Condens water connection R $\frac{3}{4}$ "
7. Sink 3 l/sek
8. Exhaust heat recovery unit
9. Alternative electrical connection
10. Alternative cold water connection R $\frac{1}{2}$ " 250-600 kPa 11 l/min
11. Alternative hot water connection R $\frac{1}{2}$ " 100-600 kPa
12. Alternative drain connection \varnothing 50
13. Non-return valve
14. Vacuum valve
15. Output detergent dosing
16. Main switch
17. Servicing clearance

CONNECTION TO ROLLER TABLE OR BENCH

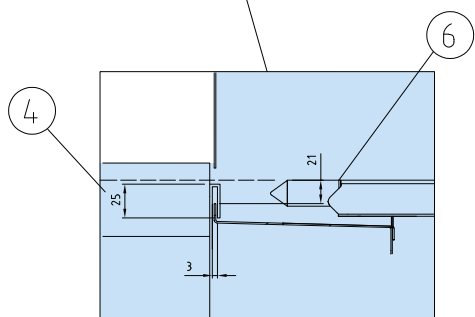
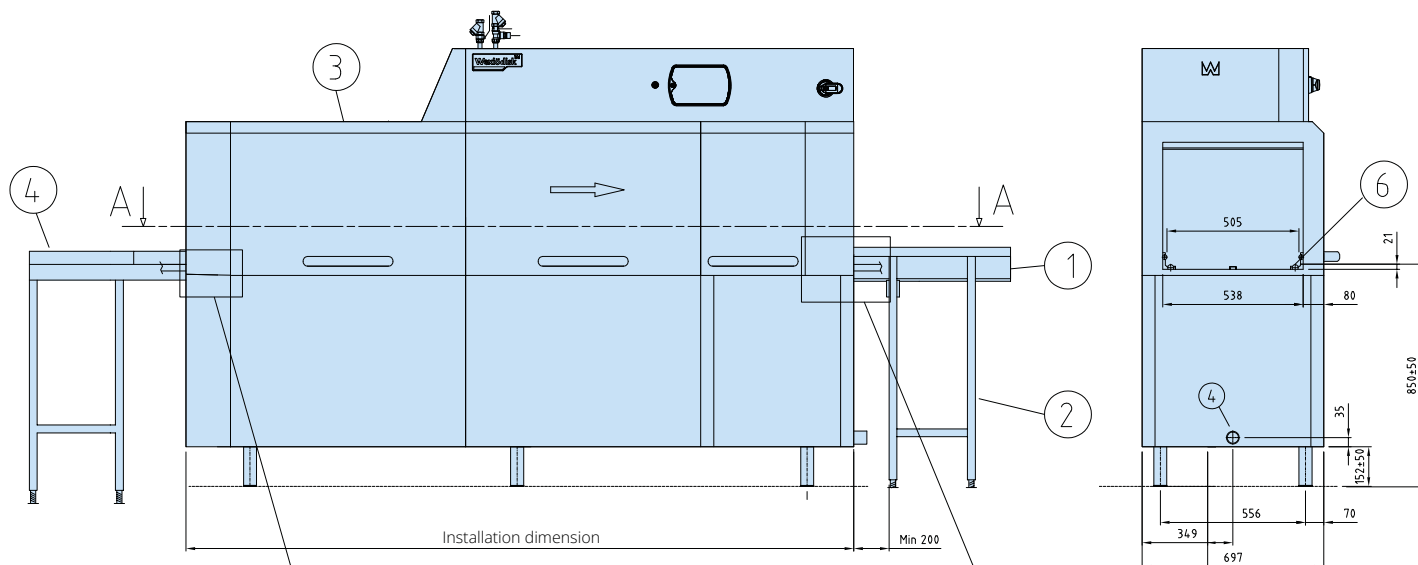

Connection to infeed

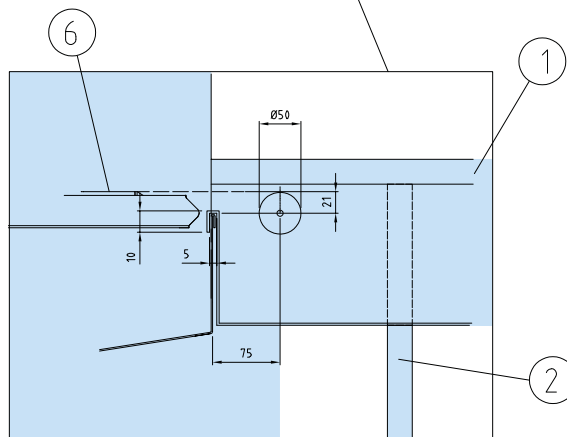

Connection to outfeed

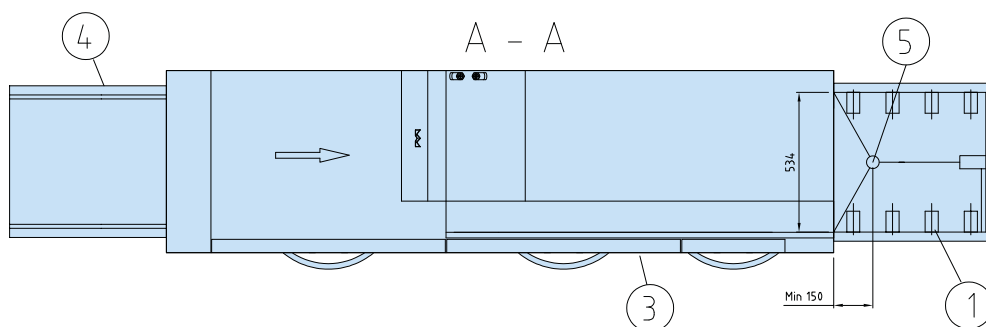

- 1. Roller table
- 2. Leg
- 3. Dishwasher
- 4. Bench
- 5. Drain
- 6. Loading cradle

We reserve the right to change technical data.

Wexiödisk

TELEPHONE: +46 470 77 12 00 FAX: +46 470 237 52 ADDRESS: Mårdvägen 4 SE-352 45 Växjö SWEDEN
E-MAIL: wexiodisk@wexiodisk.com WEBB: www.wexiodisk.com