

HIGH TEMP PIZZA OVENS

P-SERIES - HIGH TEMP PIZZA OVEN

Developed to bake pizza and breads that requires high temperatures - **up to 500°C / 932°F!** Bake Neapolitan pizza, pitas, lavash and more in an electrical oven of highest quality, without firewood, fire or flue gases. The oven is fitted with Italian Biscotto di Sorrento Pizza stones, traditionally made in Italy. The stone, plus the highly efficient heating element which provides a fast and even heat distribution in the stainless steel oven chamber, the ceramic glass in the door and the robust design, makes High Temp Pizza Oven one of the most energy efficient and reliable high-temperature ovens on the market.

FEATURES AND BENEFITS

Max baking temperature 500°C / 932°F.

Pizza stone of highest quality.
Authentic Biscotto di Sorrento Pizza stones from Italy.

Highly efficient heating system.
High-quality heating system that distributes the heat more even and effectively.

No naked flames or need for firewood.
Easy to use, no firewood, flames, toxic smoke or fumes, and more reliable heating in the oven.

Fast baking time. Bake pizza in 60 to 120 seconds.
The baking time may vary according to the choice of topping.

Fast heating of oven. Ready to bake in approximately 30 minutes from start-up.
Depending on preferred baking temperature. With the programmable week timer (with start settings), plan your week and arrive to an already heated oven.

Strong, spring loaded precision-built door with ergonomic, cool handles.
Robust, easy to open and keep clean.

Automatic Turbo start function.
Automatically heats up the oven quickly to the set temperature. Demands no manual setup from the user.

Digital control panel with energy saving timer.
Makes the oven both energy efficient and easy to use.

Heat reflecting ceramic glass.
Withstand temperature changes. Keeps the heat inside the oven.

Strong insulation.
Ensures that the heat stays in the oven chamber. Energy efficient and cost saving. The high level of insulation ensures a better working environment.

Effective working high temperature resistant double halogen lighting.
Provides whiter and more intensive working light than standard bulbs.

Robust legs with lockable wheels.
Keeps the oven in place and enable it to be moved for cleaning.

Pullout shelves.
The two sliding shelves come with a standard stopping mechanism. Use for storage or extra working space.



High Temp Pizza Oven



DOUGH FOR HIGH TEMP BAKING

Bear in mind that baking a Neapolitan pizza at higher temperatures requires a dough with plenty of water – we recommend about 60-70% – with finely ground Tipo 00 flour.

OPTIONS

Door with double glazed window.



TECHNICAL & MEASUREMENTS [MM]

Maximum baking temperature	500°C / 932°F
Baking surface	0.76 m ²
Baking area (stone hearth) mm WxD	1065 x 715 mm
Capacity pizza Ø 35 cm	6 pizzas
Power	12.5 kW / 13.5 kW ¹
External dimensions WxHxD	1475 x 1725 x 1010 mm
Internal dimensions WxHxD	1070 x 169 x 725 mm
Door opening height	140 mm
Exhaust duct, Ø 125 mm*	100-125 m ³ /h
Weight	186 kg
Leg height	1000 mm

*Connection diameter

¹Applies to model 3x415V+N

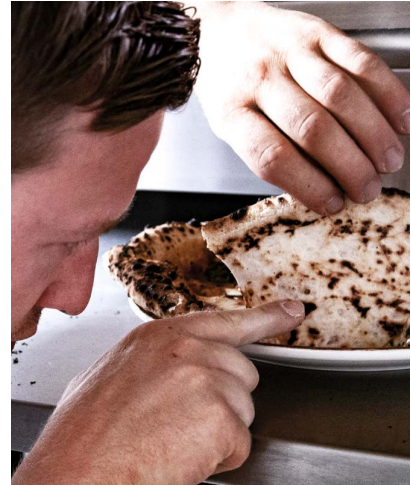

Front

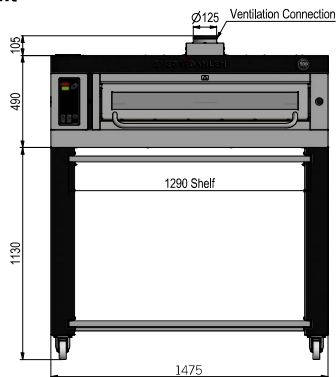

Side

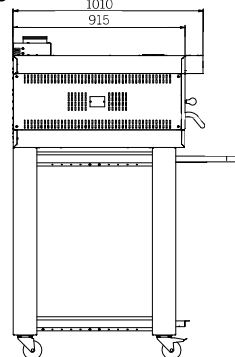

MAXIMUM BAKING SURFACE

