

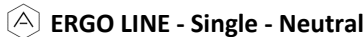

Technical Specification

Model Serie



Product Models

Article Number

NE08

ELSNE08

NE10

ELSNE10

NE12

ELSNE12

NE14

ELSNE14

Capacity

Standard	GN 1/1	GN 1/1	GN 1/1	GN 1/1
Distance between levels	80 mm	80 mm	80 mm	80 mm
Number of 65 mm containers	8	10	12	14
Number of 100 mm containers	5	7	8	9
Number of 150 mm containers	3	4	5	6
Maximum load per rack	9 kg	9 kg	9 kg	9 kg
Maximum load in unit	72 kg	90 kg	108 kg	126 kg
Max total weight (full unit)	115 kg	140 kg	160 kg	180 kg

Physical Attributes

External dimensions (W x H x D) mm	540 x 1064 x 810	540 x 1224 x 810	540 x 1384 x 810	540 x 1545 x 810
Internal dimensions (W x H x D) mm	352 x 727 x 600	352 x 887 x 600	352 x 1047 x 600	352 x 1207 x 600
Volume	154 Liter	187 Liter	221 Liter	255 Liter
Net weight (empty unit)	44 kg	48 kg	52 kg	57 kg
Door opening	270°	270°	270°	270°

Dimension drawings

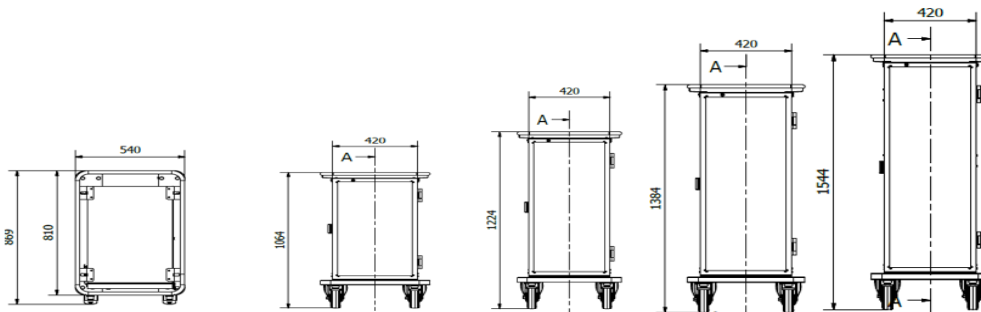

*1 - Vertical Push / pull handles standard on ELSNE14