

PRM 60/90

FEATURES

- Ergonomic – replaces the repetitive manual pre-rinsing movement that can lead to occupational injuries
- Economic – unique reuse of washing water from the rack conveyor dishwasher provides significant overall water savings
- Better wash results – effective rinsing and soaking of soiled items which at the same time reduces the rinsing water consumption
- Easy cleaning and good accessibility
- Rinse the dishes, both from above as well as underneath the basket
- Efficient rinsing system removes food residue and has the same effect as soaking during the time the basket is transported to the dishwasher
- Function for rinse cleaning of PRM with separate push button in front



TECHNICAL DATA	PRM-60	PRM-90
Pump (kW)	0,75	0,75
Tank volume (litres)	30	30
Weight, machine in operation (kg)	150	170
Degree of protection (IP)	55	55

CAPACITY AND OPERATING DATA	PRM-60	PRM-90
Max. surface temp. at room temp. 20°C (°C)	35	35
Sound level*** (dB(A))	68	68

* Measured 1 metre from the side of the machine

CONNECTION, ELECTRICALLY HEATED	PRM-60	PRM-90
Total connected power (kW)	0,8	0,8
Main fuse 400V 3N~(A)*	10	10
Max. connection area 400V 3N~(L1-L3, N, PE) Cu (mm ²)	6	6
Electrical connection of the PRM by the dishwasher	Option	Option

* Other voltages on request

** Delivered with 3 meter cable

CONNECTION, WATER, DRAIN AND VENTILATION	PRM-60	PRM-90
Drain connection, PP pipe (ø mm)	50	50
Water connection from dish machine (ø mm)	50	50
Floor drain, capacity (litres/sec)	3	3
Ventilation of the machine (m ³ /h)	200	200

SIZE AND WEIGHT	PRM-60	PRM-90
Size** (LxWxH (m))	0,6x0,7x1,4	0,95x0,95x1,4
Weight** (kg)	155	175

* Normal delivery in 1 piece, If necessary the machine can be further dismantled

** Packaging included

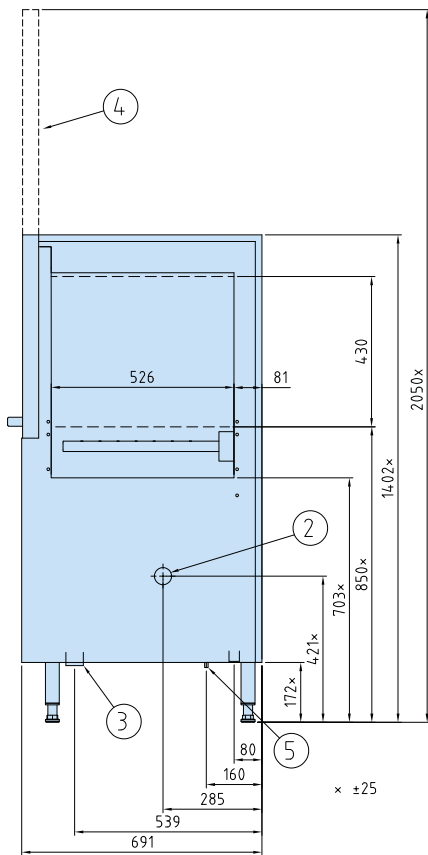

PRM-60

1. Electrical connection *
2. Water connection from dishwasher R 1/2"
3. Drain
4. Door (open position)

* can be electrically connected by the dishwasher

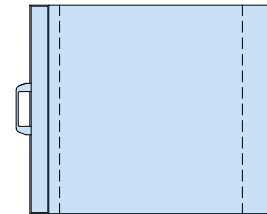
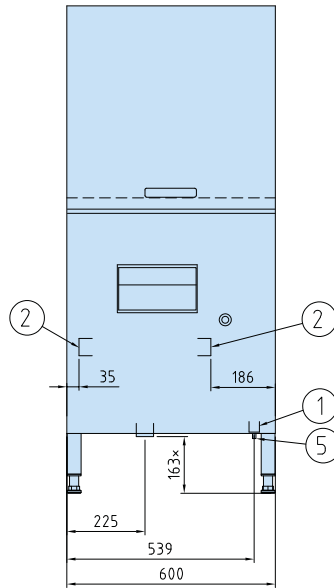

PRM-90

1. Electrical connection *
2. Water connection from dishwasher R 1/2"
3. Drain
4. Door (open position)

* can be electrically connected by the dishwasher

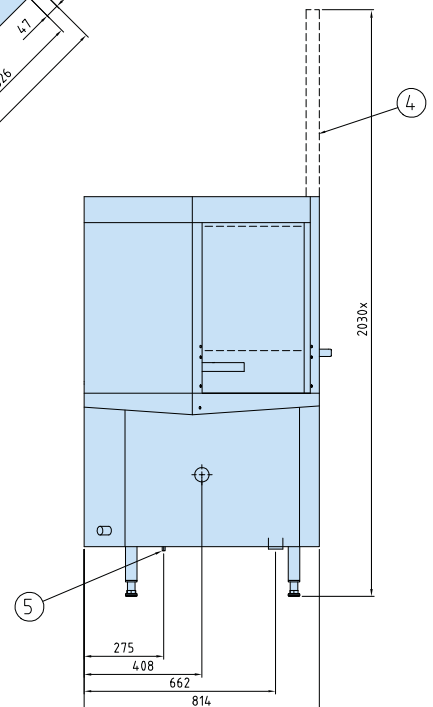
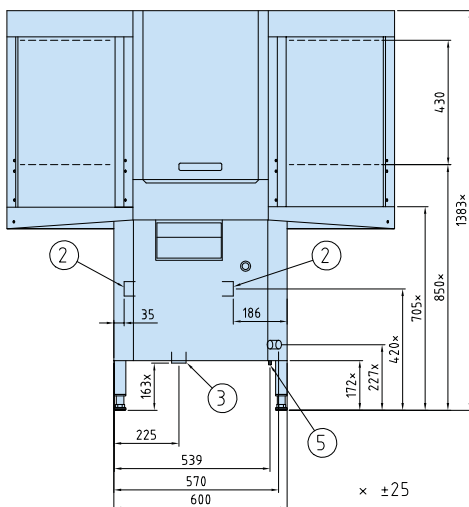
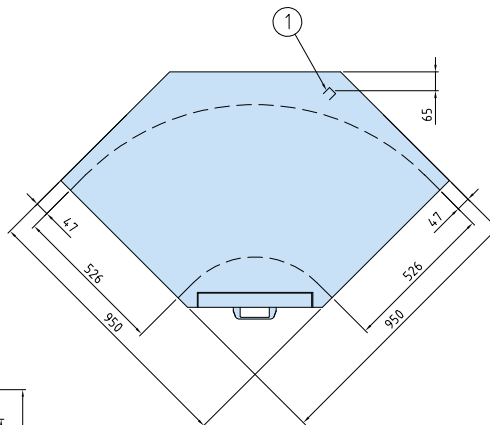



ACCESSORIES

RACK CONVEYOR DISHWASHER

CORNER LOADING UNIT

- The corner loading unit is ideal for loading dishwashers in smaller spaces.
- Connected to the machine's feeder and does not require an extra motor.
- Available for both right and leftloading machines.
- The frame is made from stainless steel and fitted with adjustable feet.
- Standard length 630 mm.
- Special lengths 631 - 2785 mm.



90° OR 180° MOTOR-POWERED TURN TRACK

- Made entirely from stainless steel.
- Frame made from 30x30 mm square stainless steel tubing with adjustable feet.
- Suitable for all 50x50 cm washing baskets.
- The baskets are loaded using a plastic drive chain.
- Equipped with an emergency stop.
- Connected to the machine's unloading side, either directly to the machine or to a straight section placed between the machine and the track.
- It can also be placed on the loading side.



ROLLER TABLE

- Designed to be connected directly to a dishwasher or a turn track.
- Made entirely of stainless steel and has a frame made of sturdy square tubing. It has a sloping base and a drain connection which can be connected to the floor drain or the turn track.
- The baskets are moved on durable plastic rollers with robust bearings.
- The table is available in a fixed version or a pivoting version with locking castors. It can also be fitted with different types of shelves and, if necessary, a limit switch.



POWERED ACCESSORIES	LENGTH MM	WIDTH MM	HEIGHT MM	ELECTRICAL CONNECTION
WD-C 90 Powered turn track 90° H-V	790	790	905 +/- 25 mm	230/400V, 3N~, 50Hz, 0,12kW
WD-C 90 Powered turn track 90° V-H	790	790	905 +/- 25 mm	230/400V, 3N~, 50Hz, 0,12kW
WD-C 180 Powered turn track 180° H-V	790	1340	905 +/- 25 mm	230/400V, 3N~, 50Hz, 0,12kW
WD-C 180 Powered turn track 180° V-H	790	1340	905 +/- 25 mm	230/400V, 3N~, 50Hz, 0,12kW
Corner feeding unit ICS+	603	603	870 +/- 25 mm	
Corner feeding unit ICS+ special	631-2785	603	870 +/- 25 mm	
Other accessories				

CONNECTION TO ROLLER TABLE OR BENCH

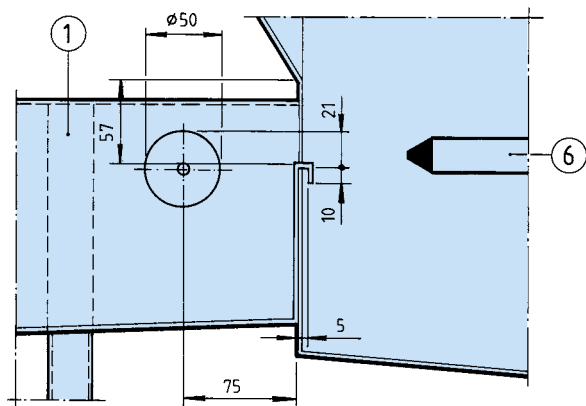
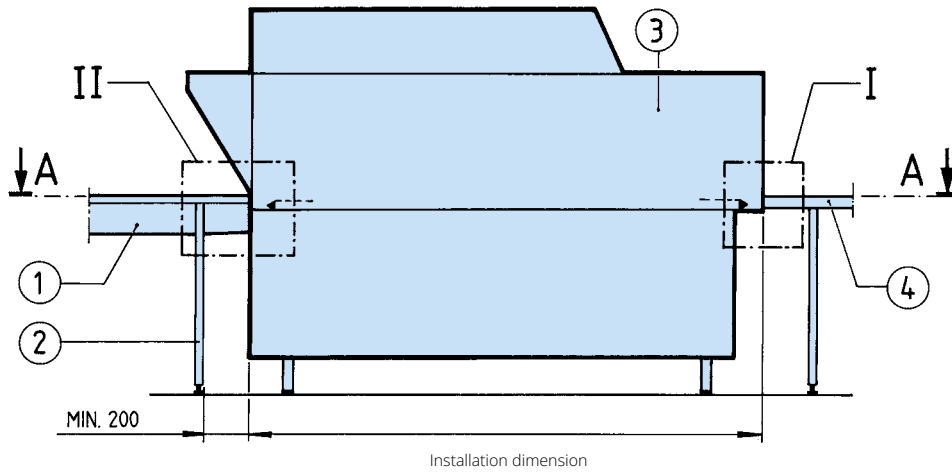

Connection to roller table (II)

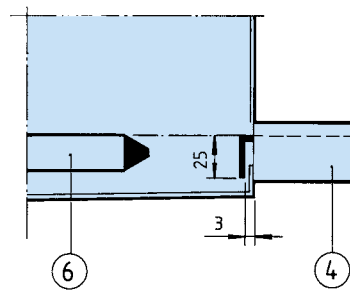

Connection to bench (I)

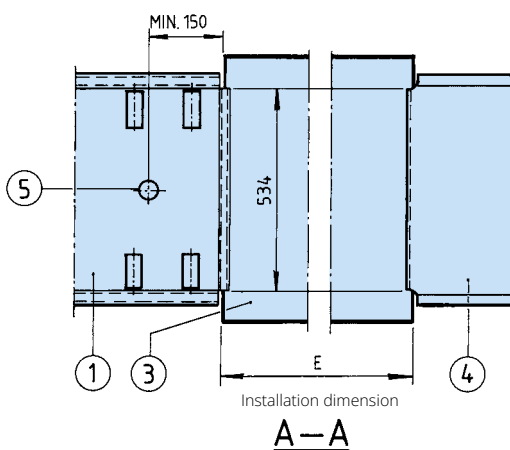

- 1. Roller table
- 2. Leg
- 3. Dishwasher
- 4. Bench
- 5. Drain
- 6. Loading cradle

Wexiödisk